



**treasury**

Department  
Treasury  
PROVINCE OF KWAZULU-NATAL

**GOVERNMENT VEHICLE CHECKLIST**

**VEHICLE REGISTRATION NUMBER:** \_\_\_\_\_ **VEHICLE LOCATION:** \_\_\_\_\_

**VEHICLE MAKE / MODEL:** \_\_\_\_\_ **AUTHORITY NO:** \_\_\_\_\_

<b><u>PRE-INSPECTION</u></b>	<b><u>POST-INSPECTION</u></b>
DATE: _____	DATE: _____
TIME: _____	TIME: _____
FUEL: F $\frac{3}{4}$ $\frac{1}{2}$ $\frac{1}{4}$ E	FUEL: F $\frac{3}{4}$ $\frac{1}{2}$ $\frac{1}{4}$ E
FUEL TANK CAPACITY: _____	FUEL TANK CAPACITY: _____
KILOMETERS START: _____	KILOMETERS END: _____
Starting Point: _____	End Point: _____
REASON: _____ _____ _____	TOTAL KILOMETERS USED _____ REASON: _____ _____ _____
NAME OF DRIVER: _____	NAME OF DRIVER: _____
SECTION/DIRECTORATE: _____	SECTION/DIRECTORATE: _____
CONTACT NUMBER: _____	CONTACT NUMBER: _____
<b>VEHICLE &amp; PETROL CARD ISSUED TO:</b>	<b>VEHICLE &amp; PETROL CARD RETURNED BY:</b>
ISSUED BY: _____	RETURNED BY: _____
RECEIVED BY: _____	SIGNATURE: _____
SIGNATURE: _____	

**PRE- INSPECTION**

TYRE PRESSURE: FL FR  
FL FR  
BODY DENT ECT: **YES/NO**  
OIL: HIGH OR LOW  
JACK: **YES/NO**  
SPAREWHEEL: **YES/NO**  
WHEEL SPANNER: **YES/NO**  
TRIANGLE: **YES/NO**  
VALID DISK: **YES/NO**

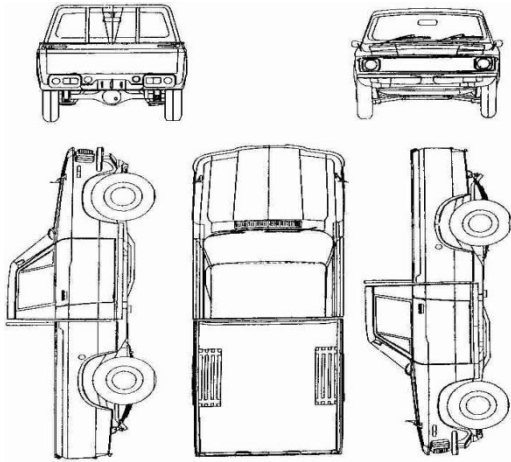
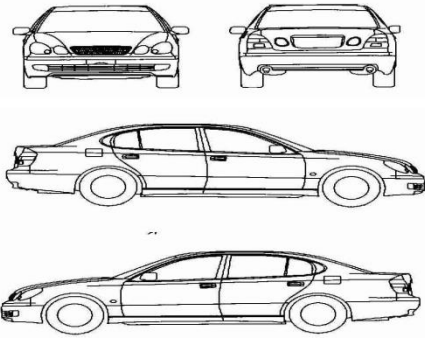

**POST - INSPECTION**

TYRE PRESSURE: FL FR  
FL FR  
BODY DENT ECT: **YES/NO**  
OIL: HIGH OR LOW  
JACK: **YES/NO**  
SPAREWHEEL: **YES/NO**  
WHEEL SPANNER: **YES/NO**  
TRIANGLE: **YES/NO**  
VALID DISK: **YES/NO**

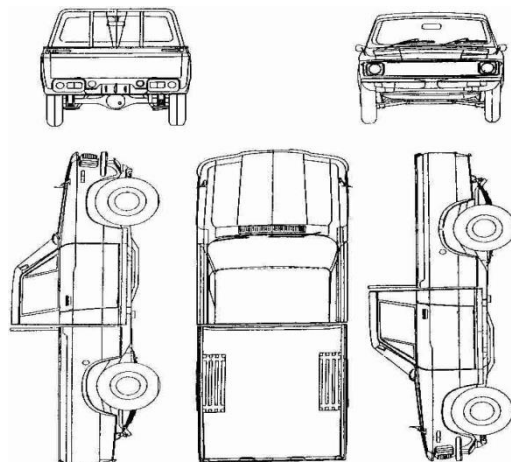
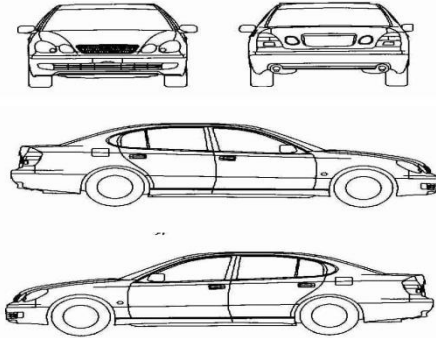

**VEHICLE INSPECTION AND ISSUE: IS THE VEHICLE ROADWORTHY: YES/NO**

SIGNATURE OF DRIVER  
PRIOR TRIP: \_\_\_\_\_

SIGNATURE OF TRANSPORT OFFICER

BEFORE: \_\_\_\_\_

SIGNATURE OF DRIVER  
AFTER TRIP: \_\_\_\_\_

SIGNATURE OF TRANSPORT OFFICER

AFTER TRIP: \_\_\_\_\_